

SITECOM

User manual



Powerbank 20.000 mAh 30 Watt Power Delivery

APB-200RDG v1 001

APB-200RLG v1 001

APB-200RPK v1 001

APB-200RGN v1 001



EN At a glance
DE Auf einen Blick
BG Обобщение
CZ Stručný přehled
ES De un vistazo

FR Aperçu
GR Με μια ματιά
HR Na prvi pogled
IT In un colpo d'occhio
NL In één oogopslag

PL Rzutem oka
PT Em breve
RO Dintr-o privire
SI Na hitro
SK V skratke

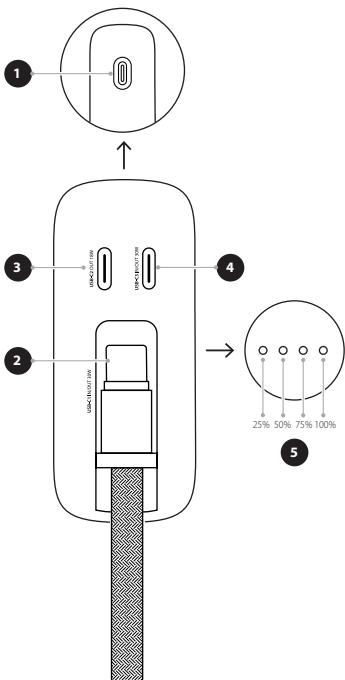

- A** **EN** - Charge your powerbank / **DE** - Deine Powerbank aufladen / **BG** - Заредете вашата powerbank / **CZ** - Nabijte powerbanku / **ES** - Carga tu powerbank / **FR** - Chargez votre powerbank / **GR** - Φορτίστε το powerbank σας / **HR** - Napuni svoj powerbank / **IT** - Carica il tuo powerbank / **NL** - Laad je powerbank op / **PL** - Ładowanie powerbanku / **PT** - Carrega o teu powerbank / **RO** - Încărcați-vă bateria externă / **SI** - Napolnite vašo prenosno baterijo / **SK** - Nabite svoju powerbanku

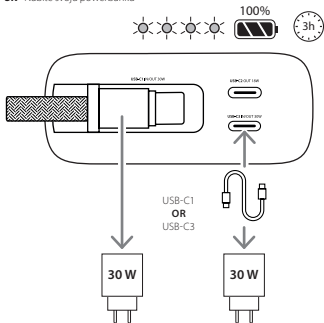

- B** **EN** - Charge your device / **DE** - Dein Gerät aufladen / **BG** - Заредете вашето устройство / **CZ** - Nabijte zařízení / **ES** - Carga tu dispositivo / **FR** - Chargez votre appareil / **GR** - Φορτίστε τη συσκευή σας / **HR** - Napuni svoj uređaj / **IT** - Carica il tuo dispositivo / **NL** - Laad je apparaat op / **PL** - Ładowanie podłączonego urządzenia / **PT** - Carrega o teu aparelho / **RO** - Încărcați-vă dispozitivul / **SI** - Napolnite vašo napravo / **SK** - Nabite svoju zariadenie

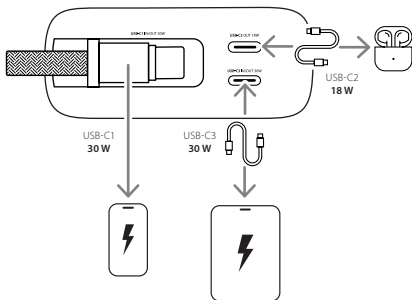

EN - At a glance

Item	Specifications	Description
1 Power button		Press 1x to turn on. Press 2x to turn off.
2 USB-C1 in / out (cable)	Power in / out: 5.0 V \equiv 3.0 A (15.0 W), 9.0 V \equiv 3.0 A (27.0 W), 12.0 V \equiv 2.5 A (30.0 W), 15.0 V \equiv 2.0 A (30.0 W), 20.0 V \equiv 1.5 A (30.0 W)	To charge your powerbank, connect a wall charger with the integrated USB-C cable. (A) To charge your device, connect the device with the integrated USB-C cable. (B)
3 USB-C2 out	Power out: 5.0 V \equiv 3.0 A (15.0 W), 9.0 V \equiv 2.0 A (18.0 W), 12.0 V \equiv 1.5 A (18.0 W)	To charge your device, connect the device with a USB-C cable to the USB-C port. (B)
4 USB-C3 in / out	Power in / out: 5.0 V \equiv 3.0 A (15.0 W), 9.0 V \equiv 3.0 A (27.0 W), 12.0 V \equiv 2.5 A (30.0 W), 15.0 V \equiv 2.0 A (30.0 W), 20.0 V \equiv 1.5 A (30.0 W)	To charge your powerbank, connect a wall charger with a USB-C cable to the USB-C port. (A) To charge your device, connect the device with a USB-C cable to the USB-C port. (B)
5 Status lights	LED lights	Status lights indicate the powerbank battery level (0% to 100%). During charging 1 LED will flash depending on the battery level. When the battery is fully charged all LEDs are on.

Other specifications	
Internal battery type	Rechargeable Li-ion Polymer
Cell energy	10000 mAh/3.85 V/38.5 Wh (two cells in series)
Battery energy	10000 mAh/7.7 V/77 Wh
Power input	USB-C1/C3: 5.0 V \equiv 3.0 A (15.0 W), 9.0 V \equiv 3.0 A (27.0 W), 12.0 V \equiv 2.5 A (30.0 W), 15.0 V \equiv 2.0 A (30.0 W), 20.0 V \equiv 1.5 A (30.0 W)
Power output	USB-C1/C3: 5.0 V \equiv 3.0 A (15.0 W), 9.0 V \equiv 3.0 A (27.0 W), 12.0 V \equiv 2.5 A (30.0 W), 15.0 V \equiv 2.0 A (30.0 W), 20.0 V \equiv 1.5 A (30.0 W) USB-C2: 5.0 V \equiv 3.0 A (15.0 W), 9.0 V \equiv 2.0 A (18.0 W), 12.0 V \equiv 1.5 A (18.0 W) USB-C1+USB-C2/USB-C1+USB-C3/USB-C2+USB-C3/USB-C1+USB-C2+USB-C3: 5.0 V \equiv 3.0 A (15.0 W)
Charge time	Charge the powerbank to 100% in 3 hours at 30.0 W
Safety	Overcharge, discharge, overload, short circuit, overcurrent and overheat protection
Airplane safe	Yes, UN38.3
Supported devices	Charge USB-C devices with an operating voltage of 5.0 V, 9.0 V, 12.0 V, 15.0 V, 20.0 V direct current, like phones and tablets. To charge the powerbank please use a 30.0 W USB-C PD charger
Dimensions	118 x 71 x 29.6 mm
Weight	335 gram

Important safety instructions

- Do not throw, drop, shake and avoid strong blows and collisions
 - Do not disassemble or modify
 - Do not burn or incinerate
 - Do not use near inflammable materials or explosive gases
 - Do not expose to excessive heat or excessive cold
 - Avoid abrupt changes in temperature
 - Do not expose to liquids
 - Do not use or store in damp, humid or wet environments
 - Do not cover with objects which may affect heat dissipation
 - Avoid contact with battery chemicals
 - Disconnect when not in use, do not charge or discharge unattended
 - Keep out of reach of children
-

Support

Warranty	36 months warranty. Please note that your rights under national law remain unaffected by this warranty.
Support	Lifetime technical support
Website	www.sitecom.com
Contact	support@sitecom.com

DE - Auf einen Blick

Artikel	Spezifikationen	Beschreibung
1 Power-Taste		Zum Einschalten 1x drücken. Zum Ausschalten 2x drücken.
2 USB-C1 Ein-/Ausgang (Kabel)	Stromeingang/-ausgang: 5.0 V \equiv 3.0 A (15.0 W), 9.0 V \equiv 3.0 A (27.0 W), 12.0 V \equiv 2.5 A (30.0 W), 15.0 V \equiv 2.0 A (30.0 W), 20.0 V \equiv 1.5 A (30.0 W)	Um deine Powerbank aufzuladen, verbinde ein Wandladegerät mit dem integrierten USB-C-Kabel. (A) Um dein Gerät aufzuladen, verbinde das Gerät mit dem integrierten USB-C-Kabel. (B)
3 USB-C2 Ausgang	Ausgangsleistung: 5.0 V \equiv 3.0 A (15.0 W), 9.0 V \equiv 2.0 A (18.0 W), 12.0 V \equiv 1.5 A (18.0 W)	Um dein Gerät aufzuladen, verbinde es mit einem USB-C-Kabel mit dem USB-C-Anschluss. (B)
4 USB-C3 Ein-/Ausgang	Stromeingang/-ausgang: 5.0 V \equiv 3.0 A (15.0 W), 9.0 V \equiv 3.0 A (27.0 W), 12.0 V \equiv 2.5 A (30.0 W), 15.0 V \equiv 2.0 A (30.0 W), 20.0 V \equiv 1.5 A (30.0 W)	Um deine Powerbank aufzuladen, verbinde ein Wandladegerät mit einem USB-C-Kabel mit dem USB-C-Anschluss. (A) Um dein Gerät aufzuladen, verbinde es mit einem USB-C-Kabel mit dem USB-C-Anschluss. (B)
5 Statusleuchten	LED-Lichter	Statusleuchten zeigen den Akkuladestand der Powerbank an (0 % bis 100 %). Während des Ladevorgangs blinkt je nach Akkustand 1 LED. Wenn der Akku vollständig aufgeladen ist, leuchten alle LEDs.

Andere Spezifikationen

Interner Batterietyp	Wiederaufladbares Li-Ion Polymer
Zellenergie	10000 mAh/3.85 V/38.5 Wh (zwei Zellen in Reihe)
Batterieenergie	10000 mAh/7.7 V/77 Wh
Leistungsaufnahme	USB-C1/C3: 5.0 V \equiv 3.0 A (15.0 W), 9.0 V \equiv 3.0 A (27.0 W), 12.0 V \equiv 2.5 A (30.0 W), 15.0 V \equiv 2.0 A (30.0 W), 20.0 V \equiv 1.5 A (30.0 W)
Leistung	USB-C1/C3: 5.0 V \equiv 3.0 A (15.0 W), 9.0 V \equiv 3.0 A (27.0 W), 12.0 V \equiv 2.5 A (30.0 W), 15.0 V \equiv 2.0 A (30.0 W), 20.0 V \equiv 1.5 A (30.0 W) USB-C2: 5.0 V \equiv 3.0 A (15.0 W), 9.0 V \equiv 2.0 A (18.0 W), 12.0 V \equiv 1.5 A (18.0 W) USB-C1+USB-C2/USB-C1+USB-C3/USB-C2+USB-C3/USB-C1+USB-C2+USB-C3: 5.0 V \equiv 3.0 A (15.0 W)
Aufladezeit	Lade die Powerbank in 3 Stunden bei 30.0 W auf 100 % auf
Sicherheit	Überladungs-, Entladungs-, Überlast-, Kurzschluss-, Überstrom- und Überhitzungsschutz
Flugzeugsicher	Ja, UN38.3
Unterstützte Geräte	Lade USB-C Geräte mit einer Betriebsspannung von 5.0 V, 9.0 V, 12.0 V, 15.0 V, 20.0 V Gleichstrom, wie Telefone und Tablets. Zum Aufladen der Powerbank verwende bitte ein 30.0 W USB-C PD Ladegerät.
Maße	118 x 71 x 29.6 mm
Gewicht	335 Gramm

Wichtige Sicherheitsanweisungen

- Nicht werfen, fallen lassen, schütteln und starke Schläge und Zusammenstöße vermeiden
 - Nicht zerlegen oder modifizieren
 - Nicht verbrennen oder einäschern
 - Nicht in der Nähe von brennbaren Materialien oder explosiven Gasen verwenden
 - Nicht übermäßiger Hitze oder übermäßiger Kälte aussetzen
 - Abrupte Temperaturänderungen vermeiden
 - Nicht irgendwelchen Flüssigkeiten aussetzen
 - Nicht in dunstigen, feuchten oder nassen Umgebungen verwenden oder aufbewahren
 - Nicht mit Gegenständen abdecken, die die Wärmeableitung beeinträchtigen könnten
 - Kontakt mit Batteriechemikalien vermeiden
 - Bei Nichtgebrauch abtrennen, nicht unbeaufsichtigt laden oder entladen
 - Außerhalb der Reichweite von Kindern aufbewahren
-

Support

Garantie	36 Monate Garantie. Bitte beachte, dass deine Rechte nach nationalem Recht von dieser Garantie unberührt bleiben.
Support	Lebenslanger technischer Support
Website	www.sitecom.com
Kontakt	support@sitecom.com

BG - Обобщение

Артикул	Спецификации	Описание
1 Бутон за включване		Натиснете 1 път, за да включите. Натиснете 2 пъти, за да изключите.
2 USB-C1 вход/изход (кабел)	Захранване вход /изход: 5.0 V \equiv 3.0 A (15.0 W), 9.0 V \equiv 3.0 A (27.0 W), 12.0 V \equiv 2.5 A (30.0 W), 15.0 V \equiv 2.0 A (30.0 W), 20.0 V \equiv 1.5 A (30.0 W)	За да заредите външната батерия, свържете Стенно зарядно устройство към вградения USB-C кабел. (A) За да заредите устройството, свържете го към вградения USB-C кабел. (B)
3 USB-C2 изход	Захранване изход: 5.0 V \equiv 3.0 A (15.0 W), 9.0 V \equiv 2.0 A (18.0 W), 12.0 V \equiv 1.5 A (18.0 W)	За да заредите вашето устройство, свържете го с USB-C кабел към USB-C порта. (B)
4 USB-C3 вход/изход	Захранване вход /изход: 5.0 V \equiv 3.0 A (15.0 W), 9.0 V \equiv 3.0 A (27.0 W), 12.0 V \equiv 2.5 A (30.0 W), 15.0 V \equiv 2.0 A (30.0 W), 20.0 V \equiv 1.5 A (30.0 W)	За да заредите вашата външна батерия, свържете зарядно устройство към стената с USB-C кабел към USB-C порта. (A) За да заредите вашето устройство, свържете устройството с USB-C кабел към USB-C порта. (B)
5 Светлини за състояние	LED светлини	Индикаторите за състояние показват нивото на батерията на Powerbank (0% до 100%). По време на зареждане 1 светодиод ще мига в зависимост от нивото на батерията. Когато батерията е напълно заредена, всички светодиоди светят.

Други спецификации

Вътрешен тип батерия	Презареждаема литиево-йонна полимерна
Енергия на клетката	10000 mAh/3.85 V/38.5 Wh (две клетки последователн)
Енергия на батерията	10000 mAh/7.7 V/77 Wh
Входна мощност	USB-C1/C3: 5.0 V \equiv 3.0 A (15.0 W), 9.0 V \equiv 3.0 A (27.0 W), 12.0 V \equiv 2.5 A (30.0 W), 15.0 V \equiv 2.0 A (30.0 W), 20.0 V \equiv 1.5 A (30.0 W)
Изходна мощност	USB-C1/C3: 5.0 V \equiv 3.0 A (15.0 W), 9.0 V \equiv 3.0 A (27.0 W), 12.0 V \equiv 2.5 A (30.0 W), 15.0 V \equiv 2.0 A (30.0 W), 20.0 V \equiv 1.5 A (30.0 W) USB-C2: 5.0 V \equiv 3.0 A (15.0 W), 9.0 V \equiv 2.0 A (18.0 W), 12.0 V \equiv 1.5 A (18.0 W) USB-C1+USB-C2/USB-C1+USB-C3/USB-C2+USB-C3/USB-C1+USB-C2+USB-C3: 5.0 V \equiv 3.0 A (15.0 W)
Време за зареждане	Заредете powerbank до 100% за 3 часа при 30.0 W
Безопасност	Защита от презареждане, разреждане, претоварване, късо съединение, свръхток и прегряване
Сигурност при полет със самолет Airplane safe	Да, UN38.3
Поддържани устройства	Можете да заредите usb устройства с работно напрежение 5.0 V, 9.0 V, 12.0 V, 15.0 V, 20.0 V постоянен ток, като телефони и таблети. За да заредите външната батерия, използвайте 30.0 W USB-C PD зарядно устройство

Размери	118 x 71 x 29.6 mm
Тегло	335 грама

Важни инструкции за безопасност

- Не хвърляйте, изпускате, разклащайте и избягвайте силни удари и сблъсъци
 - Не разглобявайте и не модифицирайте
 - Не изгаряйте и не палете
 - Не използвайте в близост до запалими материали или експлозивни газове
 - Не излагайте на прекомерна топлина или прекомерен студ
 - Избягвайте резки промени в температурата
 - Не излагайте на течности
 - Не използвайте и не съхранявайте във влажна или мокра среда
 - Не покривайте с предмети, които могат да повлияят на разсейването на топлината
 - Избягвайте контакт с химикали от батерията
 - Изключете, когато не се използва, не зареждайте и не разреждайте без надзор
 - Дръжте далеч от деца
-

Поддръжка

Гаранция	36 месеца гаранция. Моля, обърнете внимание, че правата ви съгласно националното законодателство остават незасегнати от тази гаранция.
Поддръжка	Доживотна техническа поддръжка
Уебсайт	www.sitecom.com
Контакт	support@sitecom.com

CZ - Stručný přehled

Položka	Specifikace	Popis
1 Tlačítko napájení		Stiskněte 1x pro zapnutí. Stiskněte 2x pro vypnutí.
2 USB-C1 vstup/výstup (kabel)	Výkon vstup/výstup: 5.0 V \equiv 3.0 A (15.0 W), 9.0 V \equiv 3.0 A (27.0 W), 12.0 V \equiv 2.5 A (30.0 W), 15.0 V \equiv 2.0 A (30.0 W), 20.0 V \equiv 1.5 A (30.0 W)	Chcete-li powerbanku nabít, připojte k ní nástěnnou nabíječku pomocí integrovaného USB-C kabelu. (A) Pro nabítí zařízení jej připojte pomocí integrovaného USB-C kabelu. (B)
3 USB-C2 výstup	Výkon: 5.0 V \equiv 3.0 A (15.0 W), 9.0 V \equiv 2.0 A (18.0 W), 12.0 V \equiv 1.5 A (18.0 W)	Chcete-li zařízení nabít, připojte jej pomocí USB-C kabelu k USB-C portu. (B)
4 USB-C3 vstup/výstup	Výkon vstup/výstup: 5.0 V \equiv 3.0 A (15.0 W), 9.0 V \equiv 3.0 A (27.0 W), 12.0 V \equiv 2.5 A (30.0 W), 15.0 V \equiv 2.0 A (30.0 W), 20.0 V \equiv 1.5 A (30.0 W)	Chcete-li powerbanku nabít, připojte k ní nástěnnou nabíječku pomocí USB-C kabelu k USB-C portu. (A) Chcete-li zařízení nabít, připojte jej pomocí USB-C kabelu k USB-C portu. (B)
5 Světelné indikátory stavu	LED světla	Světelné indikátory stavu zobrazují úroveň nabití baterie powerbanky (0 % až 100 %). Během nabíjení bude blikat jedna LED kontrolka v závislosti na úrovni nabití baterie. Až bude baterie plně nabitá, všechny LED kontrolky se současně rozsvítí.

Další specifikace

Typ vnitřní baterie	Dobíjecí Li-ion polymerová baterie
Energie článků	10000 mAh/3.85 V/38.5 Wh (dva články zapojené sériově)
Energie baterie	10000 mAh/7.7 V/77 Wh
Příkon	USB-C1/C3: 5.0 V \equiv 3.0 A (15.0 W), 9.0 V \equiv 3.0 A (27.0 W), 12.0 V \equiv 2.5 A (30.0 W), 15.0 V \equiv 2.0 A (30.0 W), 20.0 V \equiv 1.5 A (30.0 W)
Výkon	USB-C1/C3: 5.0 V \equiv 3.0 A (15.0 W), 9.0 V \equiv 3.0 A (27.0 W), 12.0 V \equiv 2.5 A (30.0 W), 15.0 V \equiv 2.0 A (30.0 W), 20.0 V \equiv 1.5 A (30.0 W) USB-C2: 5.0 V \equiv 3.0 A (15.0 W), 9.0 V \equiv 2.0 A (18.0 W), 12.0 V \equiv 1.5 A (18.0 W) USB-C1+USB-C2/USB-C1+USB-C3/USB-C2+USB-C3/USB-C1+USB-C2+USB-C3: 5.0 V \equiv 3.0 A (15.0 W)
Doba nabíjení	Při výkonu 30.0 W nabití na 100 % za 3 hodiny
Bezpečnost	Ochrana proti přehřívání, vybití, přetížení, zkratů, nadproudu a přehřátí
Bezpečnost při letecké přepravě	Ano, UN38.3
Podporovaná zařízení	Nabíjejte zařízení USB s provozním napětím 5.0 V, 9.0 V, 12.0 V, 15.0 V, 20.0 V stejnosměrným proudem, jako jsou telefony a tablety. Pro nabítí powerbanky prosím použijte 30.0 W USB-C PD nabíječku
Rozměry	118 x 71 x 29.6 mm
Hmotnost	335 gramů

Důležité bezpečnostní pokyny

- Neházejte, nepouštějte a netřeste zařízením a zabezpečte jej před silnými nárazy a srážkami
 - Nerozebírejte zařízení ani jej nijak neupravujte
 - Nevhazujte do ohně ani nezapalujte
 - Nepoužívejte v blízkosti hořlavých materiálů nebo výbušných plynů
 - Nevystavujte nadměrnému teplu nebo přílišnému chladu
 - Vyhněte se prudkým změnám teploty
 - Nevystavujte zařízení kapalinám
 - Nepoužívejte a neskladujte zařízení v navlhém, vlhkém nebo mokřém prostředí
 - Nezakrývejte zařízení předměty, které mohou ovlivnit odvod tepla
 - Zabraňte kontaktu zařízení s chemikáliemi z baterie
 - Pokud zařízení nepoužíváte, odpojte jej; zařízení nenabíjejte ani nevybíjejte bez dozoru
 - Uchovávejte mimo dosah dětí
-

Podpora

Záruka	Záruka 36 měsíců. Vezměte prosím na vědomí, že vaše práva vyplývající z vnitrostátních právních předpisů nejsou touto zárukou dotčena.
Podpora	Doživotní technická podpora
Webové stránky	www.sitecom.com
Kontakt	support@sitecom.com

ES - De un vistazo

Artículo	Especificaciones	Descripción
1 Botón de encendido		Presiona 1x para encender. Presiona 2x para apagar.
2 USB-C1 entrada/salida (cable)	Entrada /salida de alimentación: 5.0 V \equiv 3.0 A (15.0 W), 9.0 V \equiv 3.0 A (27.0 W), 12.0 V \equiv 2.5 A (30.0 W), 15.0 V \equiv 2.0 A (30.0 W), 20.0 V \equiv 1.5 A (30.0 W)	Para cargar tu banco de energía, conecta un cargador de pared con el cable USB-C integrado. (A) Para cargar tu dispositivo, conéctalo con el cable USB-C integrado. (B)
3 USB-C2 salida	Salida de alimentación: 5.0 V \equiv 3.0 A (15.0 W), 9.0 V \equiv 2.0 A (18.0 W), 12.0 V \equiv 1.5 A (18.0 W)	Para cargar tu dispositivo, conéctalo con un cable USB-C al puerto USB-C. (B)
4 USB-C3 entrada/salida	Entrada /salida de alimentación: 5.0 V \equiv 3.0 A (15.0 W), 9.0 V \equiv 3.0 A (27.0 W), 12.0 V \equiv 2.5 A (30.0 W), 15.0 V \equiv 2.0 A (30.0 W), 20.0 V \equiv 1.5 A (30.0 W)	Para cargar tu banco de energía, conecta un cargador de pared con un cable USB-C al puerto USB-C. (A) Para cargar tu dispositivo, conéctalo con un cable USB-C al puerto USB-C. (B)
5 Luces de estado	LED lights	Las luces de estado indican el nivel de la batería del powerbank (0% a 100%). Durante la carga, 1 LED parpadeará según el nivel de la batería. Cuando la batería está completamente cargada, todos los LED están encendidos.

Otras especificaciones

Tipo de batería interna	Polímero de iones de litio recargable
Energía de la celda	10000 mAh/3.85 V/38.5 Wh (dos celdas en serie)
Energía de la batería	10000 mAh/7.7 V/77 Wh
Entrada de alimentación	USB-C1/C3: 5.0 V \equiv 3.0 A (15.0 W), 9.0 V \equiv 3.0 A (27.0 W), 12.0 V \equiv 2.5 A (30.0 W), 15.0 V \equiv 2.0 A (30.0 W), 20.0 V \equiv 1.5 A (30.0 W)
Salida de potencia	USB-C1/C3: 5.0 V \equiv 3.0 A (15.0 W), 9.0 V \equiv 3.0 A (27.0 W), 12.0 V \equiv 2.5 A (30.0 W), 15.0 V \equiv 2.0 A (30.0 W), 20.0 V \equiv 1.5 A (30.0 W) USB-C2: 5.0 V \equiv 3.0 A (15.0 W), 9.0 V \equiv 2.0 A (18.0 W), 12.0 V \equiv 1.5 A (18.0 W) USB-C1+USB-C2/USB-C1+USB-C3/USB-C2+USB-C3/USB-C1+USB-C2+USB-C3: 5.0 V \equiv 3.0 A (15.0 W)
Tiempo de carga	Carga la powerbank al 100% en 3 horas a 30.0 W
Seguridad	Protección contra descarga, sobrecarga, cortocircuito, sobrecorriente y sobrecalentamiento
Seguro para aviones	Sí, UN38.3
Dispositivos soportados	Carga dispositivos USB-C con una tensión de funcionamiento de 5.0 V, 9.0 V, 12.0 V, 15.0 V, 20.0 V de corriente continua, como teléfonos y tabletas. Para realizar el cargo del banco de energía, utiliza un cargador USB-C PD de 30.0 W.

Dimensiones	118 x 71 x 29.6 mm
Peso	335 gramos

Instrucciones de seguridad importantes

- No tirar, dejar caer, sacudir y evitar golpes y colisiones fuertes
- No desmontar ni modificar
- No quemar ni incinerar
- No utilizar cerca de materiales inflamables o gases explosivos.
- No exponer al calor ni al frío excesivo
- Evitar cambios bruscos de temperatura
- No exponer a líquidos
- No utilizar ni almacenar en ambientes húmedos o mojados.
- No cubrir con objetos que puedan afectar la disipación del calor.
- Evitar el contacto con productos químicos de la batería.
- Desconectar cuando no esté en uso, no cargar ni descargar sin supervisión
- Mantener fuera del alcance de los niños

Soporte

Garantía	36 meses de garantía. Ten en cuenta que esta garantía no afecta a los derechos que otorga la legislación nacional.
Soporte	Soporte técnico de por vida
Sitio web	www.sitecom.com
Contacto	support@sitecom.com

FR - Aperçu

Article	Caractéristiques	Description
1 Bouton d'alimentation		Appuyez 1x pour allumer. Appuyez 2x pour éteindre.
2 USB-C1 entrée / sortie (câble)	Énergie en entrée / en sortie : 5.0 V \equiv 3.0 A (15.0 W), 9.0 V \equiv 3.0 A (27.0 W), 12.0 V \equiv 2.5 A (30.0 W), 15.0 V \equiv 2.0 A (30.0 W), 20.0 V \equiv 1.5 A (30.0 W)	Pour recharger votre Powerbank, connectez un chargeur mural avec le câble USB-C intégré. (A) Pour charger votre appareil, connectez-le au câble USB-C intégré. (B)
3 USB-C2 sortie	Puissance de sortie : 5.0 V \equiv 3.0 A (15.0 W), 9.0 V \equiv 2.0 A (18.0 W), 12.0 V \equiv 1.5 A (18.0 W)	Pour charger votre appareil, connectez l'appareil avec un câble USB-C au port USB-C. (B)
4 USB-C3 entrée / sortie	Énergie en entrée / en sortie : 5.0 V \equiv 3.0 A (15.0 W), 9.0 V \equiv 3.0 A (27.0 W), 12.0 V \equiv 2.5 A (30.0 W), 15.0 V \equiv 2.0 A (30.0 W), 20.0 V \equiv 1.5 A (30.0 W)	Pour recharger votre Powerbank, connectez un chargeur mural avec un câble USB-C au port USB-C. (A) Pour charger votre appareil, connectez l'appareil avec un câble USB-C au port USB-C. (B)
5 Voyants d'état	Témoins LED	Les voyants d'état indiquent le niveau de la batterie du powerbank (0 % à 100 %). Pendant la charge, 1 LED clignotera en fonction du niveau de charge de la batterie. Lorsque la batterie est complètement chargée, toutes les LED sont allumées.

Autre caractéristiques

Type de batterie interne	Polymère Li-ion rechargeable
Énergie des cellules	10000 mAh/3.85 V/38.5 Wh (deux cellules en série)
Énergie de la batterie	10000 mAh/7.7 V/77 Wh
Alimentation électrique	USB-C1/C3: 5.0 V \equiv 3.0 A (15.0 W), 9.0 V \equiv 3.0 A (27.0 W), 12.0 V \equiv 2.5 A (30.0 W), 15.0 V \equiv 2.0 A (30.0 W), 20.0 V \equiv 1.5 A (30.0 W)
Puissance de sortie	USB-C1/C3: 5.0 V \equiv 3.0 A (15.0 W), 9.0 V \equiv 3.0 A (27.0 W), 12.0 V \equiv 2.5 A (30.0 W), 15.0 V \equiv 2.0 A (30.0 W), 20.0 V \equiv 1.5 A (30.0 W) USB-C2: 5.0 V \equiv 3.0 A (15.0 W), 9.0 V \equiv 2.0 A (18.0 W), 12.0 V \equiv 1.5 A (18.0 W) USB-C1+USB-C2/USB-C1+USB-C3/USB-C2+USB-C3/USB-C1+USB-C2+USB-C3: 5.0 V \equiv 3.0 A (15.0 W)
Temps de charge	Chargez le powerbank à 100 % en 3 heures à 30.0 W
Sécurité	Protection contre les surcharges, les décharges, les ruptures de charge, les courts-circuits, les surintensités et les surchauffes
Sans danger pour l'avion	Oui, UN38.3
Périphériques compatibles	Prend en charge des appareils USB-C avec une tension de fonctionnement de 5.0 V, 9.0 V, 12.0 V, 15.0 V ou 20.0 V en courant continu, comme les téléphones et les tablettes. Pour charger le Powerbank, veuillez utiliser un chargeur USB-C PD de 30.0 W

Dimensions	118 x 71 x 29.6 mm
Poids	335 grammes

Consignes de sécurité importantes

- Ne pas lancer, laisser tomber, secouer et éviter les coups violents et les collisions
 - Ne pas démonter ni modifier
 - Ne pas brûler ni incinérer
 - Ne pas utiliser à proximité de matériaux inflammables ou de gaz explosifs
 - Ne pas exposer à une chaleur excessive ou à un froid excessif
 - Éviter les changements brusques de température
 - Ne pas exposer aux liquides
 - Ne pas utiliser ou stocker dans des environnements humides ou humides
 - Ne pas couvrir avec des objets pouvant affecter la dissipation de la chaleur.
 - Éviter tout contact avec les produits chimiques de la batterie
 - Débrancher lorsqu'il n'est pas utilisé, ne chargez pas et ne déchargez pas sans surveillance
 - Tenir hors de portée des enfants
-

Assistance

Garantie	Garantie 36 mois. Cette garantie n'affecte en rien les droits dont vous bénéficiez en vertu de la législation nationale.
Assistance	Assistance technique à vie
Site Internet	www.sitecom.com
Nous contacter	support@sitecom.com

GR - Με μια ματιά

Είδος	Προδιαγραφές	Περιγραφή
1 Κουμπί ενεργοποίησης -απενεργοποίησης		Πατήστε 1 φορά για ενεργοποίηση. Πατήστε 2 φορές για απενεργοποίηση.
2 USB-C1 είσοδος/έξοδος (καλώδιο)	Ισχύς εισόδου/εξόδου: 5.0 V \equiv 3.0 A (15.0 W), 9.0 V \equiv 3.0 A (27.0 W), 12.0 V \equiv 2.5 A (30.0 W), 15.0 V \equiv 2.0 A (30.0 W), 20.0 V \equiv 1.5 A (30.0 W)	Για να φορτίσετε το powerbank, συνδέστε έναν Φορτιστή τοίχου με το ενσωματωμένο καλώδιο USB-C. (A) Για να φορτίσετε τη συσκευή σας, συνδέστε τη με το ενσωματωμένο καλώδιο USB-C. (B)
3 USB-C2 έξοδος	Ισχύς εξόδου: 5.0 V \equiv 3.0 A (15.0 W), 9.0 V \equiv 2.0 A (18.0 W), 12.0 V \equiv 1.5 A (18.0 W)	Για να φορτίσετε τη συσκευή σας, συνδέστε τη συσκευή με ένα καλώδιο USB-C στη θύρα USB-C. (B)
4 USB-C3 είσοδος/έξοδος	Ισχύς εισόδου/εξόδου: 5.0 V \equiv 3.0 A (15.0 W), 9.0 V \equiv 3.0 A (27.0 W), 12.0 V \equiv 2.5 A (30.0 W), 15.0 V \equiv 2.0 A (30.0 W), 20.0 V \equiv 1.5 A (30.0 W)	Για να φορτίσετε το powerbank σας, συνδέστε έναν φορτιστή τοίχου με καλώδιο USB-C στη θύρα USB-C. (A) Για να φορτίσετε τη συσκευή σας, συνδέστε τη συσκευή με ένα καλώδιο USB-C στη θύρα USB-C. (B)
5 Λυχνίες κατάστασης	Λυχνίες LED	Οι λυχνίες κατάστασης υποδεικνύουν το επίπεδο μπαταρίας του powerbank (0% έως 100%). Κατά τη διάρκεια της φόρτισης, 1 LED θα αναβοσβήσει ανάλογα με το επίπεδο της μπαταρίας. Όταν η μπαταρία είναι πλήρως φορτισμένη, όλα τα LED είναι αναμμένα.

Άλλες προδιαγραφές

Τύπος εσωτερικής μπαταρίας	Επαναφορτιζόμενη πολυμερή ιόντων λιθίου
Ενέργεια κυψέλης	10000 mAh/3.85 V/38.5 Wh (δύο κυψέλες σε σειρά)
Ενέργεια μπαταρίας	10000 mAh/7.7 V/77 Wh
Είσοδος ρεύματος	USB-C1/C3: 5.0 V \equiv 3.0 A (15.0 W), 9.0 V \equiv 3.0 A (27.0 W), 12.0 V \equiv 2.5 A (30.0 W), 15.0 V \equiv 2.0 A (30.0 W), 20.0 V \equiv 1.5 A (30.0 W)
Εξοδος ρεύματος	USB-C1/C3: 5.0 V \equiv 3.0 A (15.0 W), 9.0 V \equiv 3.0 A (27.0 W), 12.0 V \equiv 2.5 A (30.0 W), 15.0 V \equiv 2.0 A (30.0 W), 20.0 V \equiv 1.5 A (30.0 W) USB-C2: 5.0 V \equiv 3.0 A (15.0 W), 9.0 V \equiv 2.0 A (18.0 W), 12.0 V \equiv 1.5 A (18.0 W) USB-C1+USB-C2/USB-C1+USB-C3/USB-C2+USB-C3/USB-C1+USB-C2+USB-C3: 5.0 V \equiv 3.0 A (15.0 W)
Χρόνος φόρτισης	Φορτίστε το powerbank στο 100% σε 3 ώρες στα 30.0 W
Ασφάλεια	Προστασία από υπερφόρτιση, εκφόρτιση, υπερφόρτωση, βραχυκύκλωμα, υπέρταση και υπερθέρμανση
Ασφαλές για αεροπλάνα	Ναι, UN38.3
Υποστηριζόμενες συσκευές	Φορτίστε συσκευές USB-C με τάση λειτουργίας 5.0 V, 9.0 V, 12.0 V, 15.0 V, 20.0 V συνεχούς ρεύματος, όπως τηλέφωνα και tablet. Για να φορτίσετε το powerbank, χρησιμοποιήστε έναν φορτιστή USB-C PD 30.0 W

Διαστάσεις	118 x 71 x 29.6 mm
------------	--------------------

Βάρος	335 γραμμάρια
-------	---------------

Σημαντικές οδηγίες ασφαλείας

- Μην πετάτε, ρίχνετε, ανακινείτε και να αποφεύγετε έντονα χτυπήματα και τις συγκρούσεις
 - Μην αποσυναρμολογείτε ή τροποποιείτε
 - Μην καίτε ή αποτεφρώνετε
 - Μην χρησιμοποιείτε κοντά σε εύφλεκτα υλικά ή εκρηκτικά αέρια
 - Μην εκθέτετε σε υπερβολική θερμότητα ή κρύο
 - Αποφύγετε απότομες αλλαγές στη θερμοκρασία
 - Μην εκθέτετε σε υγρά
 - Μην χρησιμοποιείτε ή αποθηκεύετε σε νοτισμένο, νωπό ή υγρό περιβάλλον
 - Μην καλύπτετε με αντικείμενα που ενδέχεται να επηρεάσουν την απαγωγή θερμότητας
 - Αποφύγετε την επαφή με χημικά της μπαταρίας
 - Αποσυνδέστε όταν δεν το χρησιμοποιείτε, μην φορτίζετε ή αποφορτίζετε χωρίς επίβλεψη
 - Να φυλάσσεται μακριά από παιδιά
-

Υποστήριξη

Εγγύηση	36 месеца гаранция. Моля, обърнете внимание, че правата ви съгласно националното законодателство остават незасегнати от тази гаранция.
---------	--

Υποστήριξη	Τεχνική υποστήριξη εφ' όρου ζωής
------------	----------------------------------

Ιστότοπος	www.sitecom.com
-----------	--

Επικοινωνία	support@sitecom.com
-------------	--

HR - Na prvi pogled

Artikal	Tehnički podaci	Opis
1 Tipka za uključivanje		Pritisni 1x za uključivanje. Pritisni 2x za isključivanje.
2 USB-C1 ulaz/izlaz (kabel)	Uključivanje / izlaz : 5.0 V \equiv 3.0 A (15.0 W), 9.0 V \equiv 3.0 A (27.0 W), 12.0 V \equiv 2.5 A (30.0 W), 15.0 V \equiv 2.0 A (30.0 W), 20.0 V \equiv 1.5 A (30.0 W)	Za punjenje powerbanka, spojite zidni punjač integriranim USB-C kabelom. (A) Za punjenje uređaja, spojite uređaj integriranim USB-C kabelom. (B)
3 USB-C2 izlaz	Izlazno napajanje: 5.0 V \equiv 3.0 A (15.0 W), 9.0 V \equiv 2.0 A (18.0 W), 12.0 V \equiv 1.5 A (18.0 W)	Da bi napunio/la svoj uređaj, spoji uređaj pomoću USB-C kabela na USB-C priključak. (B)
4 USB-C3 ulaz/izlaz	Uključivanje / izlaz : 5.0 V \equiv 3.0 A (15.0 W), 9.0 V \equiv 3.0 A (27.0 W), 12.0 V \equiv 2.5 A (30.0 W), 15.0 V \equiv 2.0 A (30.0 W), 20.0 V \equiv 1.5 A (30.0 W)	Za punjenje prijenosne baterije, spojite zidni punjač s USB-C kabelom na USB-C priključak. (A) Da bi napunio/la svoj uređaj, spoji uređaj pomoću USB-C kabela na USB-C priključak. (B)
5 Statusna svjetla	LED svjetla	Statusna svjetla pokazuju razinu baterije powerbank-a (0% do 100%). Tijekom punjenja 1 LED će treptati ovisno o razini baterije. Kada je baterija potpuno napunjena, sve LED diode svijetle.

Ostale specifikacije

Vrsta unutarnje baterije	Punjivi Litij-ionski Polimer
Energija ćelije	10000 mAh/3.85 V/38.5 Wh (dvije ćelije u seriji)
Energija baterije	10000 mAh/7.7 V/77 Wh
Ulazna snaga	USB-C1/C3: 5.0 V \equiv 3.0 A (15.0 W), 9.0 V \equiv 3.0 A (27.0 W), 12.0 V \equiv 2.5 A (30.0 W), 15.0 V \equiv 2.0 A (30.0 W), 20.0 V \equiv 1.5 A (30.0 W)
Izlazna snaga	USB-C1/C3: 5.0 V \equiv 3.0 A (15.0 W), 9.0 V \equiv 3.0 A (27.0 W), 12.0 V \equiv 2.5 A (30.0 W), 15.0 V \equiv 2.0 A (30.0 W), 20.0 V \equiv 1.5 A (30.0 W) USB-C2: 5.0 V \equiv 3.0 A (15.0 W), 9.0 V \equiv 2.0 A (18.0 W), 12.0 V \equiv 1.5 A (18.0 W) USB-C1+USB-C2/USB-C1+USB-C3/USB-C2+USB-C3/USB-C1+USB-C2+USB-C3: 5.0 V \equiv 3.0 A (15.0 W)
Vrijeme punjenja	Napuni powerbank do 100% za 3 sata na 30.0 W
Sigurnost	Zaštita od prekomjernog punjenja, pražnjenja, preopterećenja, kratkog spoja, od prekomjerne struje i pregrijavanja.
Sigurno u avionu	Da, UN38.3
Podržani uređaji	Punite USB uređaje poput telefona i tableta pri radnom naponu od 5.0 V, 9.0 V, 12.0 V, 15.0 V, 20.0 V istosmjernom strujom. Za punjenje powerbanka koristite 30.0 W USB-C PD punjač

Dimenzije	118 x 71 x 29.6 mm
Težina	335 grama

Važne sigurnosne upute

- Nemoj bacati, ispuštati, tresti i izbjegavaj jake udarce i sudare
 - Nemoj rastavljati niti modificirati
 - Nemoj paliti ili spaljivati
 - Ne koristi u blizini zapaljivih materijala ili eksplozivnih plinova
 - Nemoj izlagati pretjeranoj toplini ili pretjeranoj hladnoći
 - Izbjegavaj nagle promjene temperature
 - Ne izlaži tekućinama
 - Nemoj koristiti ili skladištiti u vlažnom, ovlaženom ili mokrom okruženju
 - Ne prekrivaj predmetima koji mogu utjecati na rasipanje topline
 - Izbjegavaj kontakt s baterijskim kemikalijama
 - Isključi bateriju kada nije u upotrebi, nemoj je puniti niti prazniti bez nadzora
 - Čuvaj izvan dohvata djece
-

Podrška

Jamstvo	Jamstvo 36 mjeseca. Imaj na umu da ovo jamstvo ne utječe na tvoja prava prema nacionalnom zakonu.
Podrška	Doživotna tehnička podrška
Web stranica	www.sitecom.com
Kontakt	support@sitecom.com

IT - In un colpo d'occhio

Articolo	Specifiche	Descrizione
1 Tasto di accensione		Premere 1 volta per accendere. Premere 2 volte per spegnere.
2 USB-C1 ingresso / uscita (cavo)	Potenza in ingresso/uscita: 5.0 V \equiv 3.0 A (15.0 W), 9.0 V \equiv 3.0 A (27.0 W), 12.0 V \equiv 2.5 A (30.0 W), 15.0 V \equiv 2.0 A (30.0 W), 20.0 V \equiv 1.5 A (30.0 W)	Per ricaricare il tuo powerbank, collega un caricatore da parete con il cavo USB-C integrato. (A) Per ricaricare il tuo dispositivo, collegalo con il cavo USB-C integrato. (B)
3 USB-C2 uscita	Potenza in uscita: 5.0 V \equiv 3.0 A (15.0 W), 9.0 V \equiv 2.0 A (18.0 W), 12.0 V \equiv 1.5 A (18.0 W)	Per caricare il dispositivo, collegalo alla porta USB-C mediante un cavo USB-C. (B)
4 USB-C3 ingresso / uscita	Potenza in ingresso/uscita: 5.0 V \equiv 3.0 A (15.0 W), 9.0 V \equiv 3.0 A (27.0 W), 12.0 V \equiv 2.5 A (30.0 W), 15.0 V \equiv 2.0 A (30.0 W), 20.0 V \equiv 1.5 A (30.0 W)	Per caricare il tuo powerbank, collega un caricatore da parete tramite un cavo USB-C alla porta USB-C. (A) Per caricare il dispositivo, collegalo alla porta USB-C mediante un cavo USB-C. (B)
5 Spie di stato	Spie LED	Le spie di stato indicano il livello di carica della batteria del powerbank (da 0 a 100%). Durante la ricarica, 1 LED lampeggia in funzione del livello di carica della batteria. Quando la batteria è completamente carica, tutti i LED si accendono.

Altre specifiche

Tipo di batteria interna	Accumulatore litio-polimero
Energia della cella	10000 mAh/3.85 V/38.5 Wh (due celle in serie)
Energia della batteria	10000 mAh/7.7 V/77 Wh
Ingresso alimentazione	USB-C1/C3: 5.0 V \equiv 3.0 A (15.0 W), 9.0 V \equiv 3.0 A (27.0 W), 12.0 V \equiv 2.5 A (30.0 W), 15.0 V \equiv 2.0 A (30.0 W), 20.0 V \equiv 1.5 A (30.0 W)
Potenza in uscita	USB-C1/C3: 5.0 V \equiv 3.0 A (15.0 W), 9.0 V \equiv 3.0 A (27.0 W), 12.0 V \equiv 2.5 A (30.0 W), 15.0 V \equiv 2.0 A (30.0 W), 20.0 V \equiv 1.5 A (30.0 W) USB-C2: 5.0 V \equiv 3.0 A (15.0 W), 9.0 V \equiv 2.0 A (18.0 W), 12.0 V \equiv 1.5 A (18.0 W) USB-C1+USB-C2/USB-C1+USB-C3/USB-C2+USB-C3/USB-C1+USB-C2+USB-C3: 5.0 V \equiv 3.0 A (15.0 W)
Tempo di ricarica	Carica il tuo powerbank al 100% in 3 ore con una potenza di 30.0 W
Sicurezza	Protezione da sovraccarico, scarica eccessiva, sovraccarico, cortocircuito, sovracorrente e surriscaldamento
Sicuro in aereo	Sì, UN38.3
Dispositivi supportati	Ricarica dispositivi USB-C con una tensione di esercizio di 5.0 V, 9.0 V, 12.0 V, 15.0 V, 20.0 V in corrente continua, come smartphone e tablet. Per ricaricare il powerbank, usa un caricatore USB-C PD da 30.0 W.
Dimensioni	118 x 71 x 29.6 mm
Peso	335 grammi

Importanti istruzioni di sicurezza

- Non lanciare, far cadere, scuotere ed evitare forti colpi e urti
 - Non smontare né modificare
 - Non bruciare né incenerire
 - Non utilizzare in prossimità di materiali infiammabili o gas esplosivi
 - Non esporre a calore o freddo eccessivo
 - Evitare gli sbalzi di temperatura
 - Non esporre a sostanze liquide
 - Non utilizzare né conservare in ambienti umidi, bagnati o con forte evaporazione
 - Non coprire con oggetti che potrebbero incidere sulla dissipazione del calore
 - Evitare il contatto con i prodotti chimici contenuti nella batteria
 - Scollegare quando non in uso, sorvegliare mentre si carica o scarica
 - Tenere fuori dalla portata dei bambini
-

Assistenza

Garanzia	36 mesi di garanzia. Ti preghiamo di notare che, ai sensi della legislazione nazionale, la presente garanzia non pregiudica i tuoi diritti.
Assistenza	Assistenza tecnica a vita
Sito web	www.sitecom.com
Come contattarci	support@sitecom.com

NL - In één oogopslag

Item	Specificaties	Beschrijving
1 Aan/uit-knop		Druk 1x om in te schakelen. Druk 2x om uit te schakelen.
2 USB-C1 in/uit (kabel)	Ingangsvermogen / uitgangsvermogen: 5.0 V \equiv 3.0 A (15.0 W), 9.0 V \equiv 3.0 A (27.0 W), 12.0 V \equiv 2.5 A (30.0 W), 15.0 V \equiv 2.0 A (30.0 W), 20.0 V \equiv 1.5 A (30.0 W)	Om je powerbank op te laden, sluit je een wandoplader met de geïntegreerde USB-C-kabel aan. (A) Om je apparaat op te laden, sluit je het met de geïntegreerde USB-C-kabel aan. (B)
3 USB-C2 uit	Uitgangsvermogen: 5.0 V \equiv 3.0 A (15.0 W), 9.0 V \equiv 2.0 A (18.0 W), 12.0 V \equiv 1.5 A (18.0 W)	Om je apparaat op te laden, sluit je het apparaat met een USB-C kabel aan op de USB-C poort. (B)
4 USB-C3 in/uit	Ingangsvermogen / uitgangsvermogen: 5.0 V \equiv 3.0 A (15.0 W), 9.0 V \equiv 3.0 A (27.0 W), 12.0 V \equiv 2.5 A (30.0 W), 15.0 V \equiv 2.0 A (30.0 W), 20.0 V \equiv 1.5 A (30.0 W)	Om je powerbank op te laden, sluit je een wandlader met een USB-C-kabel aan op de USB-C-poort. (A) Om je apparaat op te laden, sluit je het apparaat met een USB-C kabel aan op de USB-C poort. (B)
5 Statuslampjes	Led-lampen	Statuslampjes geven het batterijniveau van de powerbank aan (0% tot 100%). Tijdens het opladen knippert 1 led afhankelijk van het batterijniveau. Wanneer de batterij volledig is opgeladen, branden alle leds.

Andere specificaties

Intern batterijtype	Opladbaar Li-ion-polymeer
Celenergie	10000 mAh/3.85 V/38.5 Wh (twee cellen in serie)
Batterij-energie	10000 mAh/7.7 V/77 Wh
Stroomaansluiting	USB-C1/C3: 5.0 V \equiv 3.0 A (15.0 W), 9.0 V \equiv 3.0 A (27.0 W), 12.0 V \equiv 2.5 A (30.0 W), 15.0 V \equiv 2.0 A (30.0 W), 20.0 V \equiv 1.5 A (30.0 W)
Uitgangsvermogen	USB-C1/C3: 5.0 V \equiv 3.0 A (15.0 W), 9.0 V \equiv 3.0 A (27.0 W), 12.0 V \equiv 2.5 A (30.0 W), 15.0 V \equiv 2.0 A (30.0 W), 20.0 V \equiv 1.5 A (30.0 W) USB-C2: 5.0 V \equiv 3.0 A (15.0 W), 9.0 V \equiv 2.0 A (18.0 W), 12.0 V \equiv 1.5 A (18.0 W) USB-C1+USB-C2/USB-C1+USB-C3/USB-C2+USB-C3/USB-C1+USB-C2+USB-C3: 5.0 V \equiv 3.0 A (15.0 W)
Oplaadtijd	Laad de powerbank op tot 100% in 3 uur bij 30.0 W
Veiligheid	Beveiliging tegen overlading, ontlading, overbelasting, kortsluiting, overstroom en oververhitting
Vliegtuigveilig	Ja, UN38.3
Ondersteunde apparaten	Laad usb-c-apparaten op met een bedrijfsspanning van 5.0 V, 9.0 V, 12.0 V, 15.0 V of 20.0 V gelijkstroom, zoals telefoons en tablets. Gebruik een 30.0 W USB-C PD-oplader om de powerbank op te laden.

Afmetingen	118 x 71 x 29.6 mm
Gewicht	335 gram

Belangrijke veiligheidsinstructies

- Niet gooien, laten vallen, schudden en harde klappen en botsingen vermijden
 - Niet demonteren of wijzigen
 - Niet verbranden of in brand steken
 - Niet gebruiken in de buurt van brandbare materialen of explosieve gassen
 - Niet blootstellen aan overmatige hitte of overmatige kou
 - Abrupte temperatuurschommelingen vermijden
 - Niet blootstellen aan vloeistoffen
 - Niet gebruiken of bewaren in klamme, vochtige of natte omgevingen
 - Niet bedekken met voorwerpen die de warmteafvoer kunnen beïnvloeden
 - Contact met batterijchemicaliën vermijden
 - Ontkoppelen wanneer niet in gebruik, niet onbewaakt opladen of ontladen
 - Buiten bereik van kinderen houden
-

Support

Garantie	36 maanden garantie. Houd er rekening mee dat uw rechten onder de nationale wetgeving onaangetast blijven door deze garantie.
Support	Levenslange technische support
Website	www.sitecom.com
Contact	support@sitecom.com

PL - Rzutem oka

Pozycja	Informacje techniczne	Opis
1 Przycisk zasilania		Naciśnij raz, aby włączyć. Naciśnij dwa razy, aby wyłączyć.
2 USB-C1 we/wy (kabel)	Wejście/wyjście: 5.0 V \equiv 3.0 A (15.0 W), 9.0 V \equiv 3.0 A (27.0 W), 12.0 V \equiv 2.5 A (30.0 W), 15.0 V \equiv 2.0 A (30.0 W), 20.0 V \equiv 1.5 A (30.0 W)	Aby naładować powerbank, podłącz ładowarkę sieciową z zintegrowanym kablem USB-C. (A) Aby naładować urządzenie, podłącz je zintegrowanym kablem USB-C. (B)
3 USB-C2 wyjście	Moc wyjściowa: 5.0 V \equiv 3.0 A (15.0 W), 9.0 V \equiv 2.0 A (18.0 W), 12.0 V \equiv 1.5 A (18.0 W)	Aby naładować urządzenie, podłącz je do portu USB-C za pomocą kabla z wtyczką USB-C. (B)
4 USB-C3 we/wy	Wejście/wyjście: 5.0 V \equiv 3.0 A (15.0 W), 9.0 V \equiv 3.0 A (27.0 W), 12.0 V \equiv 2.5 A (30.0 W), 15.0 V \equiv 2.0 A (30.0 W), 20.0 V \equiv 1.5 A (30.0 W)	Aby naładować powerbank, podłącz ładowarkę ścienną za pomocą kabla USB-C do portu USB-C. (A) Aby naładować urządzenie, podłącz je do portu USB-C za pomocą kabla z wtyczką USB-C. (B)
5 Kontrolki stanu	Kontrolki LED	Kontrolki LED wskazują poziom naładowania akumulatorów w powerbanku (od 0% do 100%). Diody LED migają również podczas ładowania, w zależności od poziomu naładowania baterii. Gdy akumulator jest w pełni naładowany, wszystkie diody LED świecą ciągłym światłem.

Dane techniczne

Typ wewnętrznego akumulatora	Polimerowy akumulator litowo-jonowy
Energia ogniwa	10000 mAh/3.85 V/38.5 Wh (dwa ogniwa szeregowo)
Energia baterii:	10000 mAh/7.7 V/77 Wh
Moc wejściowa	USB-C1/C3: 5.0 V \equiv 3.0 A (15.0 W), 9.0 V \equiv 3.0 A (27.0 W), 12.0 V \equiv 2.5 A (30.0 W), 15.0 V \equiv 2.0 A (30.0 W), 20.0 V \equiv 1.5 A (30.0 W)
Moc wyjściowa	USB-C1/C3: 5.0 V \equiv 3.0 A (15.0 W), 9.0 V \equiv 3.0 A (27.0 W), 12.0 V \equiv 2.5 A (30.0 W), 15.0 V \equiv 2.0 A (30.0 W), 20.0 V \equiv 1.5 A (30.0 W) USB-C2: 5.0 V \equiv 3.0 A (15.0 W), 9.0 V \equiv 2.0 A (18.0 W), 12.0 V \equiv 1.5 A (18.0 W) USB-C1+USB-C2/USB-C1+USB-C3/USB-C2+USB-C3/USB-C1+USB-C2+USB-C3: 5.0 V \equiv 3.0 A (15.0 W)
Czas ładowania	Powerbank można naładować do pełna w 3 godziny, jeśli moc ładowania wynosi 30.0 W.
Bezpieczeństwo	Powerbank jest wyposażony w zabezpieczenia przed przeladowaniem, rozładowaniem, przeciążeniem, zwarciem, przetężeniem i przegrzaniem
Przeznaczony do użytku w samolotach	Tak, spełnia przepisy UN38.3
Obsługiwane urządzenia	Ładuj urządzenia USB-C o napięciu roboczym 5.0 V, 9.0 V, 12.0 V, 15.0 V, 20.0 V prądem stałym, takie jak telefony i tablety. Do ładowania powerbanku użyj ładowarki USB-C PD o mocy 30.0 W

Wymiary	118 x 71 x 29.6 mm
Waga	335 gramów

Ważne instrukcje dotyczące bezpieczeństwa

- Nie rzucaj urządzeniem, nie upuszczaj go, nie potrząśnij nim, nie narażaj go na silne uderzenia
 - Nie demontuj ani nie modyfikuj urządzenia
 - Nie przypalaj ani nie spalaj urządzenia w ogniu
 - Nie używaj urządzenia w pobliżu materiałów łatwopalnych lub gazów wybuchowych
 - Nie wystawiaj urządzenia na działanie zbyt niskich lub zbyt wysokich temperatur
 - Nie narażaj urządzenia na gwałtowne zmiany temperatur
 - Nie narażaj urządzenia na kontakt z płynami
 - Nie używaj ani nie przechowuj urządzenia w wilgotnym, zawilgoconym lub mokrym otoczeniu
 - Nie przykrywaj urządzenia przedmiotami, które mogą wpływać na odprowadzanie ciepła
 - Unikaj kontaktu z substancjami chemicznymi znajdującymi się w akumulatorze
 - Odłącz urządzenie, gdy nie jest używane. Nie ładuj ani nie rozładuj urządzenia bez nadzoru
 - Trzymaj urządzenie poza zasięgiem dzieci
-

Wsparcie

Gwarancja	36 miesięcy gwarancji. Należy pamiętać, że niniejsza gwarancja nie ma wpływu na prawa użytkownika wynikające z prawa krajowego.
Wsparcie	Dożywotnie wsparcie techniczne
Strona internetowa	www.sitecom.com
Kontakt	support@sitecom.com

PT - Em breve

Item	Especificações	Descrição
1 Botão de alimentação		Pressiona 1x para ligar. Pressiona 2x para desligar.
2 USB-C1 entrada/saída (cabo)	Poder de entrada/saída: 5.0 V \equiv 3.0 A (15.0 W), 9.0 V \equiv 3.0 A (27.0 W), 12.0 V \equiv 2.5 A (30.0 W), 15.0 V \equiv 2.0 A (30.0 W), 20.0 V \equiv 1.5 A (30.0 W)	Para carregar o seu powerbank, utilize um carregador de parede connect com cabo USB-C integrado. (A) Para carregar o seu dispositivo, utilize o cabo USB-C integrado. (B)
3 USB-C2 saída	Potência da saída: 5.0 V \equiv 3.0 A (15.0 W), 9.0 V \equiv 2.0 A (18.0 W), 12.0 V \equiv 1.5 A (18.0 W)	Para carregar o seu dispositivo, ligue-o com um cabo USB-C à porta USB-C. (B)
4 USB-C3 entrada/saída	Poder de entrada/saída: 5.0 V \equiv 3.0 A (15.0 W), 9.0 V \equiv 3.0 A (27.0 W), 12.0 V \equiv 2.5 A (30.0 W), 15.0 V \equiv 2.0 A (30.0 W), 20.0 V \equiv 1.5 A (30.0 W)	Para carregar o seu powerbank, ligue um carregador de parede com um cabo USB-C à porta USB-C. (A) Para carregar o seu dispositivo, ligue-o com um cabo USB-C à porta USB-C. (B)
5 Luzes de estado	Luzes LED	As luzes de estado indicam o nível da bateria do powerbank (0% a 100%). Durante o carregamento, 1 LED irá piscar consoante o nível da bateria. Uma vez a bateria totalmente carregada, todos os LEDs se acendem.

Outras especificações

Tipo de bateria	Polímero de lítio recarregável
Energia da célula	10000 mAh/3.85 V/38.5 Wh (duas células em série)
Energia da bateria	10000 mAh/7.7 V/77 Wh
Entrada de alimentação	USB-C1/C3: 5.0 V \equiv 3.0 A (15.0 W), 9.0 V \equiv 3.0 A (27.0 W), 12.0 V \equiv 2.5 A (30.0 W), 15.0 V \equiv 2.0 A (30.0 W), 20.0 V \equiv 1.5 A (30.0 W)
Potência da saída	USB-C1/C3: 5.0 V \equiv 3.0 A (15.0 W), 9.0 V \equiv 3.0 A (27.0 W), 12.0 V \equiv 2.5 A (30.0 W), 15.0 V \equiv 2.0 A (30.0 W), 20.0 V \equiv 1.5 A (30.0 W) USB-C2: 5.0 V \equiv 3.0 A (15.0 W), 9.0 V \equiv 2.0 A (18.0 W), 12.0 V \equiv 1.5 A (18.0 W) USB-C1+USB-C2/USB-C1+USB-C3/USB-C2+USB-C3/USB-C1+USB-C2+USB-C3: 5.0 V \equiv 3.0 A (15.0 W)
Tempo de carga	Carrega completamente o teu powerbank em 3 horas a 30.0 W
Proteção contra	Sobrecarga, descarga, curto-circuito, sobrecorrente e sobreaquecimento
Seguro para usar em avião	Sim, possui a certificação ONU38.3
Aparelhos compatíveis	Carregue dispositivos USB-C com uma tensão de funcionamento de 5.0 V, 9.0 V, 12.0 V, 15.0 V e 20.0 V em corrente contínua, como telefones e tablets. Para carregar o powerbank, utilize um carregador USB-C PD de 30.0 W.

Dimensões	118 x 71 x 29.6 mm
Peso	335 gramas

Instruções de segurança importantes

- Não atirar, deixar cair ou sacudir. Evitar choques e colisões
 - Não desmontar ou modificar
 - Não queimar ou incinerar
 - Não utilizar perto de materiais inflamáveis ou gases explosivos
 - Não expor ao calor ou frio excessivos
 - Evitar mudanças bruscas de temperatura
 - Não expor a líquidos
 - Não utilizar ou armazenar em ambientes húmidos ou molhados
 - Não cobrir com objetos que possam afetar a dissipação de calor
 - Evitar qualquer tipo de contato entre a bateria e produtos químicos
 - Desligar quando não estiver a ser utilizado. Não carregar ou descarregar sem supervisão
 - Manter fora do alcance de crianças
-

Apoio

Garantia	36 meses de garantia. Os seus direitos conferidos pela legislação nacional mantêm-se inalterados com esta garantia.
Apoio	Assistência técnica ilimitada
Página Web	www.sitecom.com
Contacto	support@sitecom.com

RO - Dintr-o privire

Articol	Specificații	Descriere
1 Buton de pornire		Apăsați 1 dată pentru a porni. Apăsați de 2x pentru a opri.
2 USB-C1 intrare/ieșire (cablul)	Intrare /ieșire: 5.0 V \equiv 3.0 A (15.0 W), 9.0 V \equiv 3.0 A (27.0 W), 12.0 V \equiv 2.5 A (30.0 W), 15.0 V \equiv 2.0 A (30.0 W), 20.0 V \equiv 1.5 A (30.0 W)	Pentru a încărca powerbankul, conectează un încărcător de perete cu cablul USB-C integrat. (A) Pentru a încărca un dispozitiv, conectați dispozitivul cu cablul USB-C integrat. (B)
3 USB-C2 ieșire	Putere de ieșire: 5.0 V \equiv 3.0 A (15.0 W), 9.0 V \equiv 2.0 A (18.0 W), 12.0 V \equiv 1.5 A (18.0 W)	Pentru a vă încărca dispozitivul, conectați dispozitivul cu un cablu USB-C la portul USB-C. (B)
4 USB-C3 intrare/ ieșire	Intrare /ieșire: 5.0 V \equiv 3.0 A (15.0 W), 9.0 V \equiv 3.0 A (27.0 W), 12.0 V \equiv 2.5 A (30.0 W), 15.0 V \equiv 2.0 A (30.0 W), 20.0 V \equiv 1.5 A (30.0 W)	Pentru a încărca bateria externă, conectați un încărcător de perete cu un cablu USB-C la portul USB-C. (A) Pentru a vă încărca dispozitivul, conectați dispozitivul cu un cablu USB-C la portul USB-C. (B)
5 Lumini de stare	Lumini LED	Luminile de stare indică nivelul bateriei pentru bateria externă (de la 0% la 100%). În timpul încărcării, 1 LED va clipi în funcție de nivelul bateriei. Când bateria este complet încărcată, toate LED-urile sunt aprinse.

Alte specificații

Tip baterie internă	Polimer Li-ion reincărcabilă
Energie celule	10000 mAh/3.85 V/38.5 Wh (două celule în serie)
Energie baterie	10000 mAh/7.7 V/77 Wh
Putere de intrare	USB-C1/C3: 5.0 V \equiv 3.0 A (15.0 W), 9.0 V \equiv 3.0 A (27.0 W), 12.0 V \equiv 2.5 A (30.0 W), 15.0 V \equiv 2.0 A (30.0 W), 20.0 V \equiv 1.5 A (30.0 W)
Putere de ieșire	USB-C1/C3: 5.0 V \equiv 3.0 A (15.0 W), 9.0 V \equiv 3.0 A (27.0 W), 12.0 V \equiv 2.5 A (30.0 W), 15.0 V \equiv 2.0 A (30.0 W), 20.0 V \equiv 1.5 A (30.0 W) USB-C2: 5.0 V \equiv 3.0 A (15.0 W), 9.0 V \equiv 2.0 A (18.0 W), 12.0 V \equiv 1.5 A (18.0 W) USB-C1+USB-C2/USB-C1+USB-C3/USB-C2+USB-C3/USB-C1+USB-C2+USB-C3: 5.0 V \equiv 3.0 A (15.0 W)
Timp de încărcare	Încărcați bateria externă până la 100% în 3 ore la 30.0 W
Siguranță	Protecție la supraîncărcare, descărcare, suprasarcină, scurtcircuit, supracurent și supraîncălzire
Sigură pentru avion	Da, UN38.3
Dispozitive acceptate	Încarcă dispozitivele USB-C cu o tensiune de funcționare de 5.0 V, 9.0 V, 12.0 V, 15.0 V, 20.0 V curent continuu, precum telefoane și tablete. Ca să încarci powerbank, folosește un încărcător USB-C PD de 30.0 W
Dimensiuni	118 x 71 x 29.6 mm
Greutate	335 grame

Instruções de segurança importantes

- Nu aruncați, scăpați, scuturați și evitați loviturile și ciocnirile puternice
 - Nu dezamblați sau modificați
 - Nu ardeți sau incinerați
 - Nu utilizați în apropierea materialelor inflamabile sau a gazelor explozive
 - Nu expuneți la căldură excesivă sau la frig excesiv
 - Evitați schimbările bruște de temperatură
 - Nu expuneți la lichide
 - Nu utilizați și nu depozitați în medii ude, umede sau umezite
 - Nu acoperiți cu obiecte care pot afecta disiparea căldurii
 - Evitați contactul cu substanțele chimice ale bateriei
 - Deconectați atunci când nu este utilizată, nu încărcați sau descărcați nesupravegheat
 - A nu se lăsa la îndemâna copiilor
-

Apoio

Garantia	36 meses de garantia. Os seus direitos conferidos pela legislação nacional mantêm-se inalterados com esta garantia.
Apoio	Assistência técnica ilimitada
Pagina Web	www.sitecom.com
Contacto	support@sitecom.com

SI - Na hitro

Postavka	Specifikacije	Opis
1 Gumb za vklop		Pritisnite enkrat za vklop. Pritisnite dvakrat za izklop.
2 USB-C1 vhod/izhod (kabel)	Vhod / izhod: 5.0 V \equiv 3.0 A (15.0 W), 9.0 V \equiv 3.0 A (27.0 W), 12.0 V \equiv 2.5 A (30.0 W), 15.0 V \equiv 2.0 A (30.0 W), 20.0 V \equiv 1.5 A (30.0 W)	Za polnjenje prenosne baterije, priključite stenski polnilnik z vgrajenim kablom USB-C. (A) Za polnjenje naprave jo priključite z vgrajenim kablom USB-C (B)
3 USB-C2 izhod	Izhod: 5.0 V \equiv 3.0 A (15.0 W), 9.0 V \equiv 2.0 A (18.0 W), 12.0 V \equiv 1.5 A (18.0 W)	Če želite napolniti svojo napravo, priključite napravo s kablom USB-C na vrata USB-C. (B)
4 USB-C3 vhod / izhod	Vhod / izhod: 5.0 V \equiv 3.0 A (15.0 W), 9.0 V \equiv 3.0 A (27.0 W), 12.0 V \equiv 2.5 A (30.0 W), 15.0 V \equiv 2.0 A (30.0 W), 20.0 V \equiv 1.5 A (30.0 W)	Za polnjenje prenosne baterije jo priključite na stenski polnilnik s kablom USB-C v vrata USB-C. (A) Če želite napolniti svojo napravo, priključite napravo s kablom USB-C na vrata USB-C. (B)
5 Lučke stanja	LED lučke	Lučke stanja prikazujejo raven napolnjenosti prenosne baterije (od 0 % do 100 %). Med polnjenjem bo 1 LED lučka utripala, odvisno od ravni napolnjenosti baterije. Ko je baterija popolnoma napolnjena, svetijo vse LED lučke.

Druge specifikacije

Vrsta notranje baterije	Litij-ionski polimer za ponovno polnjenje.
Energija celice	10000 mAh/3.85 V/38.5 Wh (dve celici zaporedno)
Energija baterije	10000 mAh/7.7 V/77 Wh
Vhodna moč USB-C	USB-C1/C3: 5.0 V \equiv 3.0 A (15.0 W), 9.0 V \equiv 3.0 A (27.0 W), 12.0 V \equiv 2.5 A (30.0 W), 15.0 V \equiv 2.0 A (30.0 W), 20.0 V \equiv 1.5 A (30.0 W)
Izhodna moč	USB-C1/C3: 5.0 V \equiv 3.0 A (15.0 W), 9.0 V \equiv 3.0 A (27.0 W), 12.0 V \equiv 2.5 A (30.0 W), 15.0 V \equiv 2.0 A (30.0 W), 20.0 V \equiv 1.5 A (30.0 W) USB-C2: 5.0 V \equiv 3.0 A (15.0 W), 9.0 V \equiv 2.0 A (18.0 W), 12.0 V \equiv 1.5 A (18.0 W) USB-C1+USB-C2/USB-C1+USB-C3/USB-C2+USB-C3/USB-C1+USB-C2+USB-C3: 5.0 V \equiv 3.0 A (15.0 W)
Čas polnjenja	Prenosno baterijo napolnite do 100 % v 3 urah pri 30.0 W
Varnost	Zaščita pred prenapolnjenostjo, praznjenjem, preobremenitvijo, kratkim stikom in pregrevanjem ter nadotokovna zaščita.
Varno za letalo	Da, UN38.3
Podprte naprave	Napolnite naprave USB z delovno napetostjo 5.0 V, 9.0 V, 12.0 V, 15.0 V, 20.0 V z enosmernim tokom, kot so telefoni in tablice. Za polnjenje prenosne baterije uporabite 30.0 W USB-C PD polnilcec
Mere	118 x 71 x 29.6 mm
Teža	335 gramov

Pomembna varnostna navodila

- Ne mečite, preprečite padce, ne stresajte in se izogibajte močnim udarcem in trkom
 - Ne razstavljajte ali spreminjajte
 - Ne kurite ali sežigajte
 - Ne uporabljajte v bližini vnetljivih materialov ali eksplozivnih plinov
 - Ne izpostavljajte previsoki vročini ali prekomernemu mrazu
 - Izogibajte se nenadnim spremembam temperature
 - Ne izpostavljajte tekočinam
 - Ne uporabljajte in ne shranjujte v vlažnem ali mokrem okolju
 - Ne prekrivajte s predmeti, ki bi lahko vplivali na izgubo toplote
 - Izogibajte se stiku s kemikalijami baterije
 - Odklopite, ko ni v uporabi, ne polnite ali praznite brez nadzora
 - Hranite izven dosega otrok
-

Podpora

Garancija	36 mesecev garancije. Upoštevajte, da ta garancija ne vpliva na vaše pravice po nacionalni zakonodaji.
Podpora	Doživljenjska tehnična podpora
Уебсайт	www.sitecom.com
Контакт	support@sitecom.com

SK - V skratke

Položka	Špecifikácie	Popis
1 Vypínač		Stlačte 1x pre zapnutie. Stlačte 2x pre vypnutie.
2 USB-C1 vstup/výstup (kábel)	Napájanie vstup / výstup: 5.0 V \equiv 3.0 A (15.0 W), 9.0 V \equiv 3.0 A (27.0 W), 12.0 V \equiv 2.5 A (30.0 W), 15.0 V \equiv 2.0 A (30.0 W), 20.0 V \equiv 1.5 A (30.0 W)	Na nabitie powerbanku pripojte nástennú nabíjačku pomocou integrovaného USB-C kábla. (A) Ak chcete nabíť zariadenie, pripojte ho pomocou integrovaného USB-C kábla. (B)
3 USB-C2 výstup	Výstupný výkon: 5.0 V \equiv 3.0 A (15.0 W), 9.0 V \equiv 2.0 A (18.0 W), 12.0 V \equiv 1.5 A (18.0 W)	Ak chcete svoje zariadenie nabíť, pripojte zariadenie pomocou kábla USB-C k portu USB-C. (B)
4 USB-C3 vstup/výstup	Napájanie vstup / výstup: 5.0 V \equiv 3.0 A (15.0 W), 9.0 V \equiv 3.0 A (27.0 W), 12.0 V \equiv 2.5 A (30.0 W), 15.0 V \equiv 2.0 A (30.0 W), 20.0 V \equiv 1.5 A (30.0 W)	Na nabitie powerbanku pripojte nástennú nabíjačku pomocou kábla USB-C k portu USB-C. (A) Ak chcete svoje zariadenie nabíť, pripojte zariadenie pomocou kábla USB-C k portu USB-C. (B)
5 Stavové svetlá	LED svetlá	Stavové kontrolky indikujú úroveň nabitia batérie powerbanky (0 % až 100 %). Počas nabíjania bliká 1 LED dióda v závislosti od úrovne nabitia batérie. Keď je batéria úplne nabitá, všetky LED diódy svietia.

Iné špecifikácie

Typ internej batérie	Nabíjateľný lítium-iónový polymér
Energia článkov	10000 mAh/3.85 V/38.5 Wh (dva články zapojené sériovo)
Energia batérie	10000 mAh/7.7 V/77 Wh
Príkon	USB-C1/C3: 5.0 V \equiv 3.0 A (15.0 W), 9.0 V \equiv 3.0 A (27.0 W), 12.0 V \equiv 2.5 A (30.0 W), 15.0 V \equiv 2.0 A (30.0 W), 20.0 V \equiv 1.5 A (30.0 W)
Výstupný výkon	USB-C1/C3: 5.0 V \equiv 3.0 A (15.0 W), 9.0 V \equiv 3.0 A (27.0 W), 12.0 V \equiv 2.5 A (30.0 W), 15.0 V \equiv 2.0 A (30.0 W), 20.0 V \equiv 1.5 A (30.0 W) USB-C2: 5.0 V \equiv 3.0 A (15.0 W), 9.0 V \equiv 2.0 A (18.0 W), 12.0 V \equiv 1.5 A (18.0 W) USB-C1+USB-C2/USB-C1+USB-C3/USB-C2+USB-C3/USB-C1+USB-C2+USB-C3: 5.0 V \equiv 3.0 A (15.0 W)
Doba nabíjania	Powerbanka sa nabíja na 100 % za 3 hodiny pri 30.0 W
Bezpečnosť	Ochrana proti prebitiu, vybitiu, preťaženiu, skratu, nadprúdu a prehriatiu
Bezpečné v lietadle	Áno, UN38.3
Podporované zariadenia	Nabíjajte zariadenia USB s prevádzkovým napätím 5.0 V, 9.0 V, 12.0 V, 15.0 V, 20.0 V jednosmerným prúdom, ako sú telefóny a tablety. Na nabíjanie powerbanku použite 30.0 W USB-C PD nabíjačku
Rozmery	118 x 71 x 29.6 mm
Hmotnosť	335 gramov

Dôležité bezpečnostné pokyny

- Nehádzajte, nepúšťajte, netraste a vyhýbajte sa silným úderom a nárazom
 - Nerozoberajte ani neupravujte
 - Nespaľujte ani neohrievajte
 - Nepoužívajte v blízkosti horľavých materiálov alebo výbušných plynov
 - Nevystavujte nadmernému teplu ani nadmernému chladu
 - Vyhňte sa prudkým zmenám teploty
 - Nevystavujte tekutinám
 - Nepoužívajte ani neskladujte v nadmerne vlhkom, vlhkom alebo mokrom prostredí
 - Nezakrývajte predmetmi, ktoré by mohli ovplyvniť rozptyl tepla
 - Zabráňte kontaktu s chemikáliami batérie
 - Odpojte, keď sa nepoužíva, nenabíjajte ani nevybíjajte bez dozoru
 - Uchovávajte mimo dosahu detí
-

Podpora

Záruka	Záruka 36 mesiacov. Upozorňujeme, že vaše práva podľa vnútroštátnych právnych predpisov zostávajú touto zárukou nedotknuté.
Podpora	Assistenza tecnica a vita
Webstránka	www.sitecom.com
Kontakt	support@sitecom.com

EN - General information

Product: Sitecom Powerbank 20.000 mAh 30 Watt Power Delivery
Model Number: APB-200RDG v1 001, APB-200RLG v1 001, APB-200RPK v1 001, APB-200RGN v1 001
Manufacturer: Fresh 'n Rebel B.V., Linatebaan 101, 3045 AH Rotterdam, The Netherlands



Conformity information

Hereby, Fresh 'n Rebel B.V. declares that this product is in compliance with directives 2011/65/EU - 2014/30/EU and all other applicable EU Regulations. The full text of the EU declaration of conformity is available at the following internet address:
<https://www.sitecom.com/cedoc/APB-200R.pdf>



Disposal of the device

The crossed out wheeled bin symbol means that this product shall not be disposed of with normal household waste. Electronic and Electrical Equipment not included in the selective sorting process are potentially dangerous for the environment and human health due to the presence of hazardous substances. Please dispose of responsibly at an approved waste or recycling facility.

DE - Allgemeine Informationen

Produkt: Sitecom Powerbank 20.000 mAh 30 Watt Power Delivery
Modellnummer: APB-200RDG v1 001, APB-200RLG v1 001, APB-200RPK v1 001, APB-200RGN v1 001
Hersteller: Fresh 'n Rebel B.V., Linatebaan 101, 3045 AH Rotterdam, Niederlande



Konformitätsinformation

Hiermit erklärt Fresh 'n Rebel B.V., dass dieses Produkt mit der Richtlinie 2011/65/EU - 2014/30/EU und allen anderen anwendbaren EU-Richtlinien übereinstimmt. Der vollständige Text der EU-Konformitätserklärung ist unter der folgenden Internetadresse verfügbar:
<https://www.sitecom.com/cedoc/APB-200R.pdf>

Entsorgung des Geräts

Das nebenstehende Symbol einer durchgestrichenen Mülltonne auf Rädern zeigt an, dass dieses Gerät der Richtlinie 2012/19/EU unterliegt. Diese Richtlinie besagt, dass Sie dieses Gerät am Ende seiner Nutzungszeit nicht mit dem normalen Haushaltsmüll entsorgen dürfen, sondern in speziell eingerichteten Sammelstellen, Wertstoffhöfen oder Entsorgungsbetrieben abgeben müssen. Diese Entsorgung ist für Sie kostenfrei. Schonen Sie die Umwelt und entsorgen Sie fachgerecht. Beim Kauf eines Neugerätes haben Sie das Recht, das entsprechende Altgerät an Ihren Händler zurückzugeben. Händler von Elektro- und Elektronikgeräten mit einer Verkaufsfläche von mindestens



400 qm sowie Lebensmittelhändler mit einer Verkaufsfläche von mindestens 800 qm, die regelmäßig Elektro- und Elektronikgeräte verkaufen, sind außerdem verpflichtet, Altgeräte unentgeltlich zurückzunehmen, auch ohne dass ein Neugerät gekauft wird, wenn die Altgeräte in keiner Abmessung größer sind als 25 cm. Client Name bietet Ihnen Rücknahmemöglichkeiten direkt in den Filialen und Märkten an. Informieren Sie sich auch bei Ihrem Händler über die Rücknahmemöglichkeiten vor Ort.

Sofern Ihr Altgerät personenbezogene Daten enthält, sind Sie selbst für deren Löschung verantwortlich, bevor Sie es zurückgeben. Sofern dies ohne Zerstörung des Altgerätes möglich ist, entnehmen Sie die alten Batterien oder Akkus sowie Lampen bevor Sie das Altgerät zur Entsorgung zurückgeben und führen Sie sie einer separaten Sammlung zu. Bei fest eingebauten Akkus ist bei der Entsorgung darauf hinzuweisen, dass das Gerät einen Akku enthält. Weitere Möglichkeiten zur Entsorgung des ausgedienten Produkts erfahren Sie bei Ihrer Gemeinde- oder Stadtverwaltung.

BG - Основна информация

Продукт: Sitecom Powerbank 20.000 mAh 30 Watt Power Delivery
Номер на модела: APB-200RDG v1 001, APB-200RLG v1 001, APB-200RPK v1 001, APB-200RGN v1 001
Производител: Fresh 'n Rebel B.V., Linatebaan 101, 3045 AH Rotterdam, Нидерландия



Информация за съответствие

С настоящото Fresh 'n Rebel B.V. декларира, че този продукт е в съответствие с директиви 2011/65/EU - 2014/30/EU и всички други приложими разпоредби на ЕС. Пълният текст на ЕС декларацията за съответствие е достъпен на следния интернет адрес:
<https://www.sitecom.com/cedoc/APB-200R.pdf>



Изхвърляне

Символът със зачеркнат кош за боклук означава, че този продукт не трябва да се изхвърля с обикновените битови отпадъци. Електронното и електрическото оборудване, което не е включено в процеса на селективно сортиране, е потенциално опасно за околната среда и човешкото здраве поради наличието на опасни вещества. Моля, изхвърлете отговорно в одобрено съоръжение за отпадъци или рециклиране.

CZ - Obecné informace

Výrobek: Sitecom Powerbank 20.000 mAh 30 Watt Power Delivery
Číslo modelu: APB-200RDG v1 001, APB-200RLG v1 001, APB-200RPK v1 001, APB-200RGN v1 001
Výrobce: Fresh 'n Rebel B.V., Linatebaan 101, 3045 AH Rotterdam, Nizozemsko



Informace o shodě

Společnost Fresh 'n Rebel B.V. tímto prohlašuje, že tento výrobek je v souladu se směrnicemi 2011/65/EU - 2014/30/EU a všemi dalšími platnými předpisy EU. Úplné znění EU prohlášení o shodě je k dispozici na následující internetové adrese:
<https://www.sitecom.com/cedoc/APB-200R.pdf>



Likvidace zařízení

Symbol přeškrtnuté nádoby na odpad znamená, že tento výrobek nesmí být likvidován společně s běžným domovním odpadem. Elektronická a elektrická zařízení, která nejsou zahrnuta do procesu selektivního třídění, jsou kvůli přítomnosti nebezpečných látek v nich potenciálně nebezpečná pro životní prostředí a lidské zdraví. Odnešte je do schváleného zařízení pro nakládání s odpady nebo recyklaci.

ES - Información general

Producto: Sitecom Powerbank 20.000 mAh 30 Watt Power Delivery
Número de modelo: APB-200RDG v1 001, APB-200RLG v1 001, APB-200RPK v1 001, APB-200RGN v1 001
Fabricante: Fresh 'n Rebel B.V., Linatebaan 101, 3045 AH Rotterdam, Países Bajos



Información de conformidad

Por la presente, Fresh 'n Rebel B.V. declara que este producto cumple con la Directiva 2011/65/EU - 2014/30/EU y todas las demás regulaciones de la UE aplicables. El texto completo de la declaración UE de conformidad está disponible en la siguiente dirección de Internet:
<https://www.sitecom.com/cedoc/APB-200R.pdf>



Eliminación del dispositivo

El símbolo del contenedor de basura tachado significa que este producto no debe eliminarse con los residuos domésticos normales. Los aparatos electrónicos y eléctricos no incluidos en el proceso de clasificación selectiva son potencialmente peligrosos para el medio ambiente y la salud humana debido a la presencia de sustancias peligrosas. Por favor, deséchelos de forma responsable en una instalación de residuos o de reciclaje autorizada.

FR - Informations générales

Produit : Sitecom Powerbank 20.000 mAh 30 Watt Power Delivery
Numéro de modèle : APB-200RDG v1 001, APB-200RLG v1 001, APB-200RPK v1 001, APB-200RGN v1 001
Fabricant : Fresh 'n Rebel B.V., Linatebaan 101, 3045 AH Rotterdam, Pays-Bas



Informations sur la conformité

Par la présente, Fresh 'n Rebel B.V. déclare que cet équipement est conforme à la directive 2011/65/EU - 2014/30/EU et à toutes les autres réglementations européennes applicables. Le texte intégral de la déclaration de conformité UE est disponible à l'adresse internet suivante :
<https://www.sitecom.com/cedoc/APB-200R.pdf>



Élimination de l'appareil

Le symbole de la poubelle barrée signifie que ce produit ne peut pas être éliminé avec les déchets ménagers usuels. Les équipements électroniques et électriques non compris dans le processus de tri sélectif sont potentiellement dangereux pour l'environnement et la santé humaine en raison de la présence de substances dangereuses. Veuillez les éliminer de manière responsable dans des centres approuvés de traitement ou recyclage des déchets.



FR

Cet appareil
et sa batterie
se recyclent

À DÉPOSER
EN MAGASIN



OU

À DÉPOSER
EN DÉCHÈTERIE



Points de collecte sur www.quefairedemesdechets.fr
Privilégiez la réparation ou le don de votre appareil !

GR - Γενικές πληροφορίες

Προϊόν: Sitecom Powerbank 20.000 mAh 30 Watt Power Delivery

Αριθμός μοντέλου: APB-200RDG v1 001, APB-200RLG v1 001, APB-200RPK v1 001, APB-200RGN v1 001

Κατασκευαστής: Fresh 'n Rebel B.V., Linatebaan 101, 3045 AH Rotterdam, Κάτω Χώρες



Πληροφορίες συμμόρφωσης

Δια του παρόντος, η Fresh 'n Rebel B.V. δηλώνει ότι αυτό το προϊόν συμμορφώνεται με τις οδηγίες 2011/65/EE - 2014/30/EE και όλους τους άλλους ισχύοντες κανονισμούς της ΕΕ. Το πλήρες κείμενο της δήλωσης συμμόρφωσης ΕΕ είναι διαθέσιμο στην ακόλουθη διαδικτυακή διεύθυνση:
<https://www.sitecom.com/cedoc/APB-200R.pdf>



Απόρριψη της συσκευής

Το σύμβολο του διαγραμμένου κάδου απορριμάτων σημαίνει ότι αυτό το προϊόν δεν πρέπει να απορρίπτεται με τα συνήθη οικιακά απορρίμματα. Ηλεκτρονικός και ηλεκτρολογικός εξοπλισμός που δεν περιλαμβάνεται στη διαδικασία επιλεκτικής διαλογής είναι δυνητικά επικίνδυνος για το περιβάλλον και την ανθρώπινη υγεία λόγω της παρουσίας επικινδύνων ουσιών. Απορρίψτε με υπευθυνότητα σε ειδικευμένη εγκατάσταση απορριμάτων ή ανακύκλωσης.

HR - Opće informacije

Proizvod: Sitecom Powerbank 20.000 mAh 30 Watt Power Delivery

Broj modela: APB-200RDG v1 001, APB-200RLG v1 001, APB-200RPK v1 001, APB-200RGN v1 001

Proizvođač: Fresh 'n Rebel B.V., Linatebaan 101, 3045 AH Rotterdam, Nizozemska



Informacije o sukladnosti

Ovime Fresh 'n Rebel B.V. izjavljujemo da je ovaj proizvod u skladu s direktivama 2011/65/EU - 2014/30/EU i svim ostalim primjenjivim propisima EU. Potpuni tekst EU izjave o sukladnosti dostupan je na sljedećoj internet adresi:
<https://www.sitecom.com/cedoc/APB-200R.pdf>



Zbrinjavanje uređaja

Simbol prekrizane kante za smeće znači da se ovaj proizvod ne smije odlagati u uobičajenim kućnim otpadom. Elektronička i električna oprema koja nije uključena u proces selektivnog razvrstavanja potencijalno je opasna za okoliš i zdravlje ljudi zbog prisutnosti opasnih tvari. Molimo te da ga odgovorno odložiš u odobrenom postrojenju za odlaganje otpada ili reciklažu.

IT - Informazioni generali

Prodotto: Sitecom Powerbank 20.000 mAh 30 Watt Power Delivery

Numero di modello: APB-200RDG v1 001, APB-200RLG v1 001, APB-200RPK v1 001, APB-200RGN v1 001

Produttore: Fresh 'n Rebel B.V., Linatebaan 101, 3045 AH Rotterdam, Paesi Bassi



Informazioni generali sulla conformità del prodotto

Con la presente, Fresh 'n Rebel B.V. dichiara che la presente apparecchiatura è conforme alla direttiva 2011/65/EU - 2014/30/EU e a tutte le altre regolamentazioni UE applicabili. L'integrità della dichiarazione di conformità UE è disponibile su:
<https://www.sitecom.com/cedoc/APB-200R.pdf>

Smaltimento del dispositivo

Il simbolo del cassonetto barrato riportato sull'apparecchiatura indica che questo prodotto non deve essere smaltito con i normali rifiuti domestici. I dispositivi elettronici ed elettrici non inclusi in un processo di riciclo sono potenzialmente pericolosi per l'ambiente e la salute umana a causa della presenza di sostanze pericolose. Si prega di smaltire l'apparecchiatura in modo responsabile presso centri idonei di raccolta differenziata o di consegnarla al rivenditore seguendo una delle seguenti modalità:

- nel caso di apparecchiature di piccolissime dimensioni (dimensioni esterne inferiori a 25 cm), consegna gratuita senza obbligo di acquisto nei negozi con superficie di vendita di apparecchiature elettriche ed elettroniche superiore ai 400 mq (modalità "uno contro zero"). Per i negozi con superficie inferiore tale modalità è facoltativa.
- nel caso di apparecchiature di dimensioni esterne superiori a 25 cm, consegna gratuita al rivenditore all'atto dell'acquisto di un prodotto equivalente (modalità "uno contro uno").



NL - Algemene informatie

Product: Sitecom Powerbank 20.000 mAh 30 Watt Power Delivery
Modelnummer: APB-200RDG v1 001, APB-200RLG v1 001, APB-200RPK v1 001, APB-200RGN v1 001
Fabrikant: Fresh 'n Rebel B.V., Linatebaan 101, 3045 AH Rotterdam, Nederland



Informatie over conformiteit

Hierbij verklaart Fresh 'n Rebel B.V. dat dit product voldoet aan de richtlijnen 2011/65/EU - 2014/30/EU en alle andere toepasselijke EU-regelgeving. De volledige tekst van de EU-conformiteitsverklaring is beschikbaar op het volgende internetadres: <https://www.sitecom.com/cedoc/APB-200R.pdf>



Afvoeren van het apparaat

Het symbool van de doorgekruiste vuilniscontainer betekent dat dit product niet met het gewone huisvuil mag worden weggegooid. Elektronische en elektrische apparatuur die niet is opgenomen in het selectieve afvalsorteringsproces is potentieel gevaarlijk voor het milieu en de menselijke gezondheid vanwege de aanwezigheid van gevaarlijke stoffen. Voer deze op verantwoorde wijze af bij een erkend afvalverwerkings- of recyclingbedrijf.

PL - Informacje ogólne

Produkt: Sitecom Powerbank 20.000 mAh 30 Watt Power Delivery
Numer modelu: APB-200RDG v1 001, APB-200RLG v1 001, APB-200RPK v1 001, APB-200RGN v1 001
Producent: Fresh 'n Rebel B.V., Linatebaan 101, 3045 AH Rotterdam, Holandia



Informacje o zgodności

Fresh 'n Rebel B.V. niniejszym oświadcza, że ten sprzęt jest zgodny z Dyrektywą 2011/65/EU - 2014/30/EU oraz innymi obowiązującymi przepisami UE. Pełny tekst deklaracji zgodności UE jest dostępny pod adresem URL: <https://www.sitecom.com/cedoc/APB-200R.pdf>



Utylizacja urządzenia

Symbol przekreślonego kołowego kontenera na odpady oznacza, że tego produktu nie można wyrzucać wraz z innymi odpadami gospodarstwa domowego. Ze względu na obecność niebezpiecznych substancji, mieszanin lub części składowych urządzenia elektryczne i elektroniczne, niepodlegające procesowi selektywnego sortowania są potencjalnie niebezpieczne dla środowiska i zdrowia ludzi. Produkt należy zutylizować w sposób odpowiedzialny w zatwierdzonym zakładzie utylizacji odpadów lub recyklingu.

PT - Informações gerais

Produtos: Sitecom Powerbank 20.000 mAh 30 Watt Power Delivery
Número do modelo: APB-200RDG v1 001, APB-200RLG v1 001, APB-200RPK v1 001, APB-200RGN v1 001
Fabricante: Fresh 'n Rebel B.V., Linatebaan 101, 3045 AH Rotterdam, Países Baixos



Informação sobre a conformidade

Por este meio, a Fresh 'n Rebel B.V. declara que este produto está em conformidade com a Directiva 2011/65/EU - 2014/30/EU e todos os outros regulamentos da UE aplicáveis. O texto completo da declaração da UE de conformidade está disponível no seguinte endereço da Internet: <https://www.sitecom.com/cedoc/APB-200R.pdf>



Eliminação do dispositivo

O símbolo do contentor de lixo sobre rodas riscado significa que este produto não deve ser eliminado com os resíduos domésticos. Os equipamentos eletrónicos e eléctricos não incluídos no processo de separação seletiva são potencialmente perigosos para o ambiente e para a saúde humana devido à presença de substâncias perigosas. Por favor, elimine-o de forma responsável num centro de reciclagem de resíduos aprovado.

RO - Informații generale

Produs: Sitecom Powerbank 20.000 mAh 30 Watt Power Delivery

Număr de model: APB-200RDG v1 001, APB-200RLG v1 001, APB-200RPK v1 001, APB-200RGN v1 001

Producător: Fresh 'n Rebel B.V., Linatebaan 101, 3045 AH Rotterdam, Olanda



Informații de conformitate

Prin prezența, Fresh 'n Rebel B.V. declară că acest produs este în conformitate cu directivele 2011/65/UE - 2014/30/UE și cu toate celelalte reglementări UE aplicabile. Textul integral al declarației UE de conformitate este disponibil la următoarea adresă de internet:
<https://www.sitecom.com/cedoc/APB-200R.pdf>



Eliminarea dispozitivului

Simbolul un coș de gunoi încercuit și tăiat indică faptul că acest produs nu trebuie eliminat împreună cu deșeurile menajere uzuale. Echipamentele Electrice și Electronice care nu sunt incluse în sistemul de colectare selectivă a deșeurilor pot fi potențial dăunătoare pentru mediul înconjurător și sănătatea umană datorită prezenței substanțelor periculoase. Vă rugăm să le eliminați în mod responsabil la o unitate autorizată de colectare sau reciclare a deșeurilor.

SI - Splošne informacije

Izdelek: Sitecom Powerbank 20.000 mAh 30 Watt Power Delivery

Številka modela: APB-200RDG v1 001, APB-200RLG v1 001, APB-200RPK v1 001, APB-200RGN v1 001

Proizvajalec: Fresh 'n Rebel B.V., Linatebaan 101, 3045 AH Rotterdam, Nizozemska



Podatki o skladnosti

S tem Fresh 'n Rebel B.V. izjavlja, da je ta izdelek v skladu z direktivama 2011/65/EU - 2014/30/EU in vsemi drugimi veljavnimi predpisi EU. Celotno besedilo izjave EU o skladnosti je na voljo na naslednjem spletnem naslovu: <https://www.sitecom.com/cedoc/APB-200R.pdf>



Odstranjevanje naprave

Simbol prečrtanega smetnjaka s kolesi, pomeni, da tega izdelka ne smete odlagati z običajnimi gospodinjstvi odpadki. Elektronska in električna oprema, ki ni vključena v postopek selektivnega sortiranja, je zaradi prisotnosti nevarnih snovi potencialno nevarna za okolje in zdravje ljudi. Odstranite odgovorno v odobrenem obratu za ravnanje z odpadki ali obratu za recikliranje.

SK - Všeobecné informácie

Výrobok: Sitecom Powerbank 20.000 mAh 30 Watt Power Delivery

Číslo modelu: APB-200RDG v1 001, APB-200RLG v1 001, APB-200RPK v1 001, APB-200RGN v1 001

Výrobca: Fresh 'n Rebel B.V., Linatebaan 101, 3045 AH Rotterdam, Holandsko



Informácie o zhode

Spoločnosť Fresh 'n Rebel B.V. týmto vyhlasuje, že tento výrobok je v súlade so smernicami 2011/65/EU - 2014/30/EU a všetkými ostatnými platnými nariadeniami EÚ. Úplné znenie vyhlásenia o zhode EÚ je k dispozícii na tejto internetovej adrese:
<https://www.sitecom.com/cedoc/APB-200R.pdf>



Likvidácia zariadenia

Symbol prečrtanej nádoby na odpad znamená, že tento výrobok sa nesmie likvidovať s bežným komunálnym odpadom. Elektronické a elektrické zariadenia, ktoré nebudú likvidované procesom selektívneho triedenia, predstavujú z dôvodu prítomnosti nebezpečných látok potenciálne nebezpečenstvo pre životné prostredie a ľudské zdravie. Zlikvidujte ich zodpovedne cez schválené zariadenia na uloženie alebo recykláciu odpadu.

EN - The packaging materials have been selected for their environmental friendliness and are recyclable. Dispose of packaging materials which are no longer needed in accordance with applicable local regulations. / DE - Die Verpackungsmaterialien wurden aufgrund ihrer Umweltfreundlichkeit ausgewählt und sind recycelbar. Bitte entsorgen Sie nicht mehr benötigte Verpackungsmaterialien gemäss den nationalen und lokalen Gesetzen und Vorschriften. / BG - Опаковъчните материали са избрани заради тяхната екологичност и могат да се рециклират. Изхвърлете опаковъчните материали, когато вече не са необходими, в съответствие с приложимите местни разпоредби. / CZ - Obalové materiály byly vybrány pro jejich šetrnost k životnímu prostředí a jsou recyklovatelné. Nepotřebné obalové materiály zlikvidujte v souladu s platnými místními předpisy. / ES - Los materiales de embalaje han sido seleccionados por su respeto al medio ambiente y son reciclables. Deseche los materiales de embalaje que ya no necesite de acuerdo con las regulaciones locales aplicables. / FR - Les matériaux d'emballage ont été sélectionnés pour leur respect de l'environnement et sont recyclables. Éliminer les matériaux d'emballage qui ne sont plus nécessaires conformément aux réglementations locales applicables. / GR - Τα υλικά συσκευασίας έχουν επιλεγεί επειδή είναι φιλικά προς το περιβάλλον και ανακυκλώσιμα. Απορρίψτε τα υλικά συσκευασίας που δεν χρειάζονται πλέον σύμφωνα με τους ισχύοντες τοπικούς κανονισμούς. / HR - Ambalažni materijali odabrani su zbog njihove ekološke prihvatljivosti i mogu se reciklirati. Odložiti ambalažni materijal koji više nije potreban u skladu s važećim lokalnim propisima. / IT - I nostri materiali di imballaggio sono riciclabili e selezionati in virtù della loro compatibilità ambientale. Smaltire i materiali di imballaggio in conformità con le normative locali vigenti. / NL - De verpakkingsmaterialen zijn geselecteerd op basis van hun milieuvriendelijkheid en zijn recyclebaar. Verpakkingsmateriaal dat niet meer nodig is, dient volgens toepasselijke plaatselijke voorschriften afgevoerd te worden. / PL - Materiały opakowaniowe zostały wybrane ze względu na ich przyjazność dla środowiska i nadają się do recyklingu. Niepotrzebne już materiały opakowaniowe należy usunąć zgodnie z obowiązującymi lokalnymi przepisami. / PT - Os nossos materiais de embalagem são recicláveis e seleccionados em virtude da sua compatibilidade ambiental. Descarte os materiais de embalagem que já não sejam necessários de acordo com os regulamentos locais aplicáveis. / RO - Materialele de ambalare au fost selectate pentru respectarea mediului și sunt reciclabile. Eliminați materialele de ambalare care nu mai sunt necesare în conformitate cu reglementările locale aplicabile. / SI - Embalažni materiali so bili izbrani zaradi njihove prijaznosti do okolja in jih je mogoče reciklirati. Embalažni material, ki ga ne potrebujete več, zavržite v skladu z veljavnimi lokalnimi predpisi. / SK - Obalové materiály boli vybrané pre ich šetrnosť k životnému prostrediu a sú recyklovateľné. Nepotrebne obalové materiály zlikvidujte v súlade s platnými miestnymi predpismi.

PACKAGING RECYCLING	
Covers	Blister
Paperboard	Plastic
	
PAPER COLLECTION	PLASTIC COLLECTION
Raccolta differenziata dei rifiuti. Controlla le linee guida del tuo comune.	
Carte	Blister
Carta PAP 21	Plastica PET 01
Raccolta carta e cartone	Raccolta plastica



SITECOM



Shell is **80%**
GRS certified
recycled PC
and **20%**
GRS certified
recycled ABS

Certified by
Control Union
CU1462115

